

STABILA®

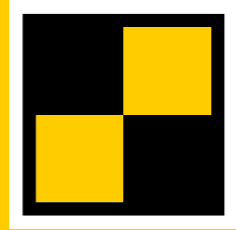

How true pro's measure

LAX 400

Operating Instructions



Contents

Section	Page
• 1. Operating Instructions	1
• 2. Before initial commissioning:	2
• 3. Safety instructions	3
• 4. Maintenance and upkeep	3
• 5. Components of the unit:	4
• 6. Inserting / Replacing the battery	5
• 7. Commissioning with levelling function	6
• 8. Selecting the laser functions	7
• 8.1 Levelling functions:	7
• 8.2 Plumb-line laser function:	8
• 9. Commissioning without levelling function	8
• 10. Additional functions	9
• 10.1 Function: Height adjustment	9
• 10.2 Function: Fine adjustment	9
• 11. Checking the accuracy	10
• 11.1 Vertical check	10
• 11.2 Horizontal check	11
• 11.3 Angle check	12
• 12. Technical data	13



1. Operating Instructions

The STABILA-LAX 400 is an easy-to-operate self-levelling multi-line laser, designed for use on building sites. The laser unit is self-levelling within the range of $\pm 4^\circ$. The fine adjustment allows precise 90° angles to be projected.

The laser lines are pulsed which makes it possible to work over greater distances using a special STABILA line receiver. For more information refer to the operating instructions for the line receiver.

? If you still have questions after reading through the operating instructions, you can obtain advice by telephone:



+49 / 63 46 / 3 09 - 0

Functions:

- 2 x vertical laser lines at a 90° angle
- 2 x cross lines
- 1 x 360° horizontal laser line
- 1 x plumb-line laser

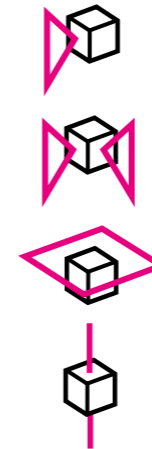

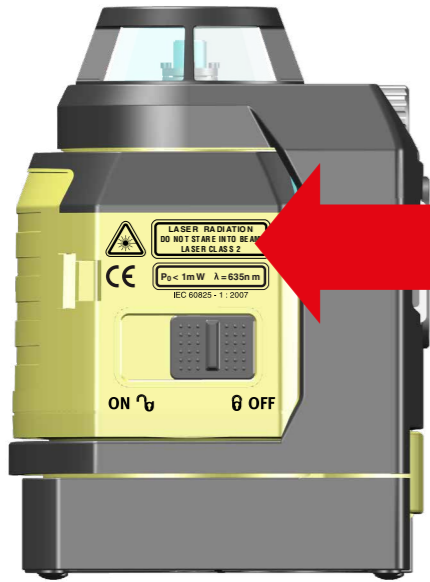

LASERSTRAHLUNG NICHT IN DEN STRAHL BLICKEN LASER KLASSE 2	LASERSTRÅLING KIG IKKE IND I STRÅLEN LASERKLASSE 2	RAZA LASER NU PRIVIȚI ÎN RAZA CLASA LASERULUI 2
LASER RADIATION AVOID DIRECT EYE EXPOSURE CLASS 2 LASER PRODUCT	LASERSTRÅLNING SE INTE IN I STRÅLEN LASERKLASS 2	AKTINOBOLIA LEIŽEP MĦN KOITAZETE STĦN AKTINA KATHĦOPIA LEIŽEP 2
RADIATION LASER NE FIXER JAMAIS LE FAISCEAU LASER CLASSE 2	LAZER IŞINI IŞINA BAKMAYINIZ LAZER SINIFI 2	Лазерное излучение на луч не смот еть класс лазера 2
RAGGIO LASER NON GUARDARE NEL RAGGIO CLASSE LASER 2	LASEROVÉ ŽARENÍ NEDIVAT SE DO PAPERSKU LASEROVÁ TRÍDA 2	LĀZERA RADIĀCIJA NESKATĪETIES STARĀ LĀZERA KLAŠE 2
RADIACIÓN LASER NO MIRAR HACIA EL RAYO LÁSER CLASE 2	LASEROVÉ ŽIARENIE NEĤADIET NA LÚC LASER TRIEDY 2	LASERAKIIRGUS ĀRA SEISA KIIRE EES LASER KLASŠ 2
LASERSTRALEN NIET IN DE STRAAL KIJKEN LASERKLASSE 2	PROMIENIOWANIE LASEROWE UNIKAĆ PATRZANENIA W ŹRÓDŁO ŚWIATKA LASER KLASY 2	LAZERIO SPINDULIUOTĒ NEŽĪŪRĒTI J SPINDULJ LAZERIO KLASĒ 2
RAIOS LASER NÃO OLHAR DIRECTAMENTE NO RAIO CLASSE DE LASER 2	LASERSKO ŽARČENJE NE GLEJTE V ŽAREK LASERSKI RAZRED 2	レーザー光線 ビームをのぞきこまないでと レーザー クラス 2
LASERSTRÅLING IKKE SE INN I STRÅLEN LASERKLASSE 2	LASERSKO ŽARČENJE NE GLEDATI U ZRAKU KLASA LASERA 2	레이저 빔 광선을 정면으로 보지 마시오 레이저 등급 2
LASERLAITE TOIMINNASSA VÄLTÄ SUORAA KATSETTA SÄTE E SEEN LASERLUOKKA 2	LÉZERSUGÁR NE NÉZZÜNK A SUGÁRBA 2. LÉZEROSZTÁLY	激光射线 切勿直视射线 激光级 2

2. Before initial commissioning:

**LASER RADIATION
DO NOT STARE INTO BEAM
CLASS 2 LASER PRODUCT**

Attach the warning label in your language to the laser unit.
Affix the adhesive label over the English text.

The relevant adhesive labels are enclosed.



- Attach the warning label in your language to the laser unit
- Read the safety instructions -> Safety instructions
- Insert batteries -> Battery replacement



3. Safety instructions

Before initial commissioning:

Carefully read the safety instructions and operating instructions.

- Only permit qualified persons to operate the unit!
- Observe the safety precautions!
- Attach the warning label in your language to the laser unit. The relevant adhesive labels are enclosed. The positioning of the labels is described in the operating instructions.

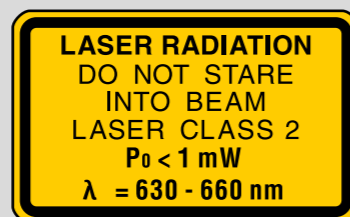

IEC 60825-1:2007



Warning:

Your eyes are normally protected by their lid closure reflex and / or a natural instinct to turn away if you accidentally look into the laser beam of class 2 laser units very briefly. If a laser beam hits your eye, consciously close your eyes and move your head out of the path of the beam. Do not look into the direct or reflected beam.

The STABILA laser goggles available with laser units are not protective goggles, rather allow the laser light to be seen more easily.

- Do not aim the laser beam directly at people!
- Avoid dazzling other people!
- Keep out of the reach of children!
- It can result in dangerous exposure to radiation if operating and adjustment equipment, or methods other than those described in these operating instructions, are used.
- Tampering (modifications) with the laser unit is not permitted.
- The unit may malfunction if it is dropped or suffers serious vibrations!
- Always check before you start work that the unit is functioning correctly and accurately, especially if it has been exposed to heavy vibrations.
- Do not use in explosive or corrosive environments!
- Do not dispose of the batteries and unit with domestic waste!
- Keep this user manual in a safe place and hand it over when passing the unit to another person.

4. Maintenance and upkeep

The STABILA laser measuring unit is an optical precision instrument and should therefore be handled with care.

Window apertures, display windows:

Dirty window glass impairs the optical function.

Only clean with a soft cloth, a little water or, if required, a mild detergent!

Casing:

Clean the unit with a damp cloth.

- Do not use solvents or thinners!
- Do not immerse the unit in water
- Do not unscrew the laser unit!

Transport and storage

- Remove the batteries if you do not intend to use the unit for some time!
- Do not store the unit when damp!
- Allow the unit and carry case to dry first if necessary.



Recycling programme for our EU customers

In accordance with WEEE rules, STABILA offers to dispose of electronic products at the end of their useful service life.

For more information call: +49 / 6346 / 309-0



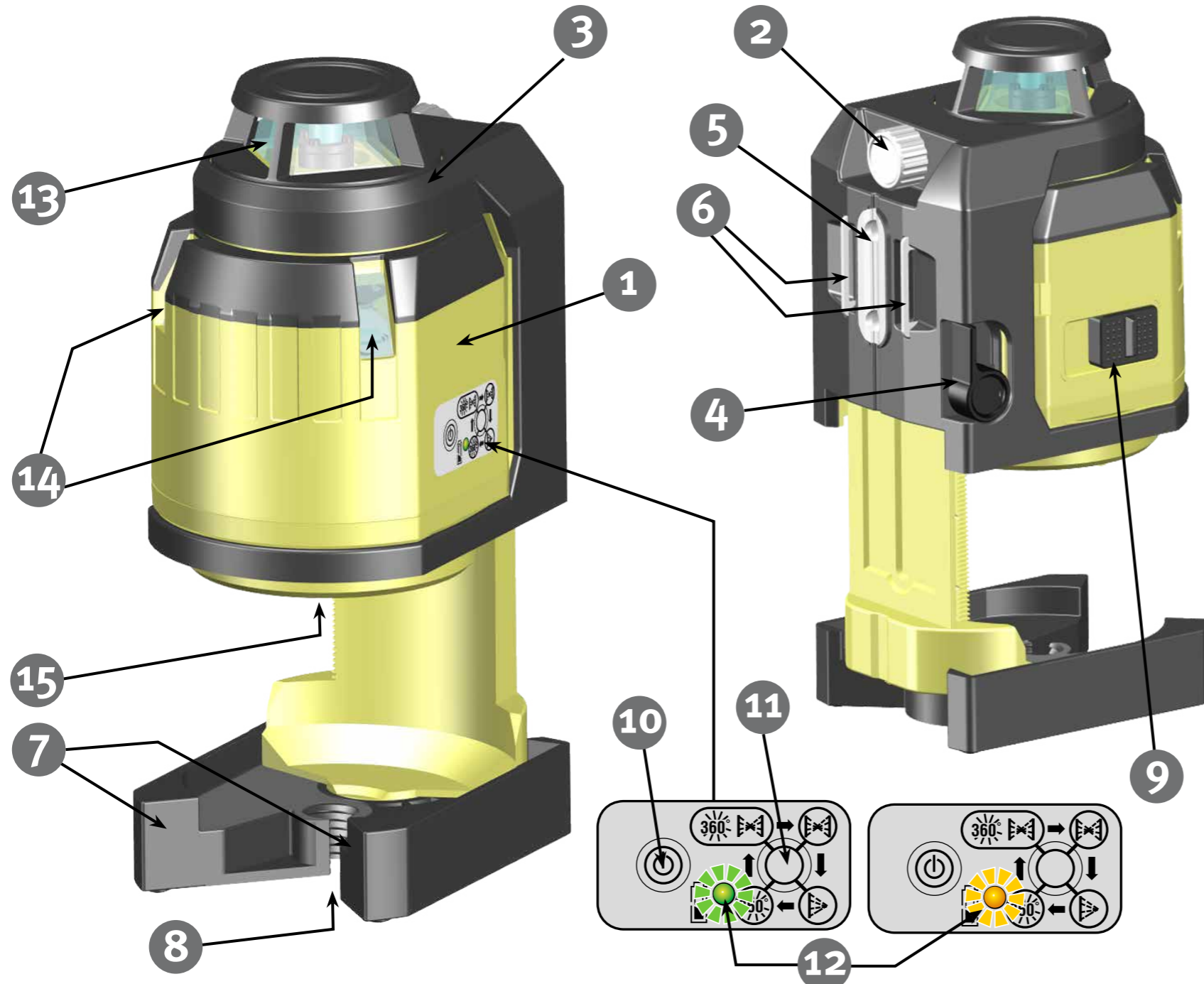

5. Components of the unit:

1. Laser casing
2. Fine adjustment
3. Casing frame
4. Height adjustment clamping lever
5. Magnet
6. Eyelets for attaching tensioning belt
7. Feet with bearing surfaces
8. 5/8" tripod socket
9. ON / OFF sliding switch with transport lock
10. ON / OFF button for marking laser
11. Button for selecting laser functions
12. Green LED: Operating function
Yellow LED: Battery charge indicator
13. Exit window for 360° laser line
14. Exit windows for vertical laser lines
15. Exit window for plumb-line laser
16. Battery compartment lid

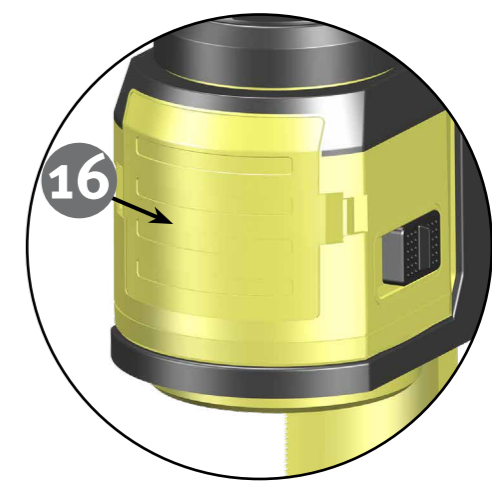
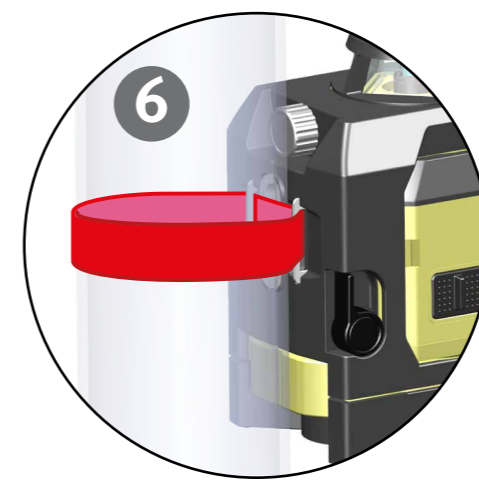
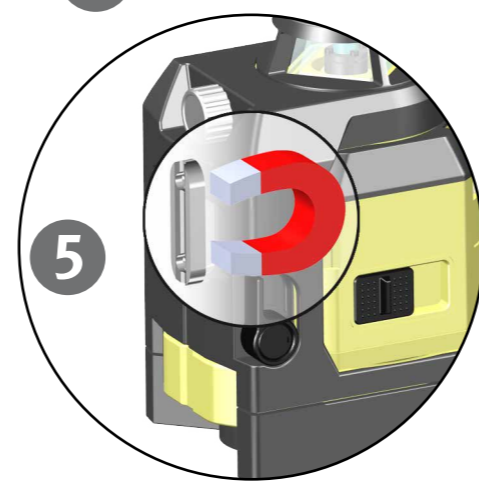
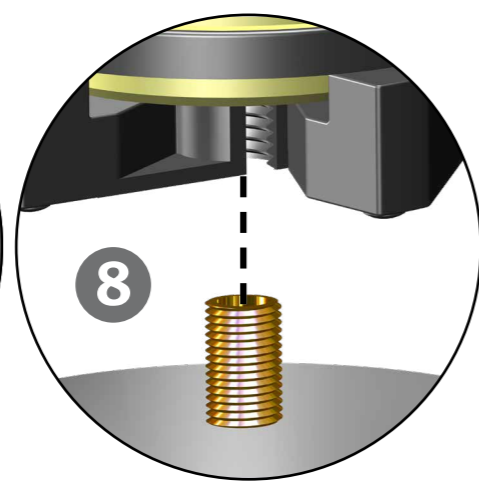
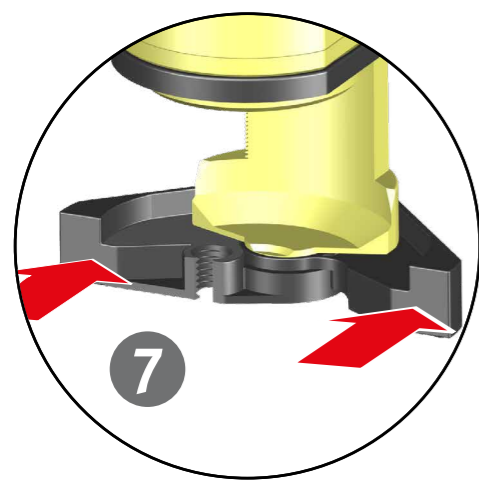

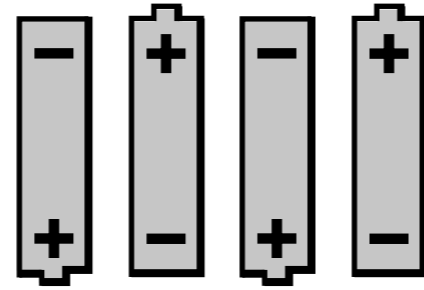
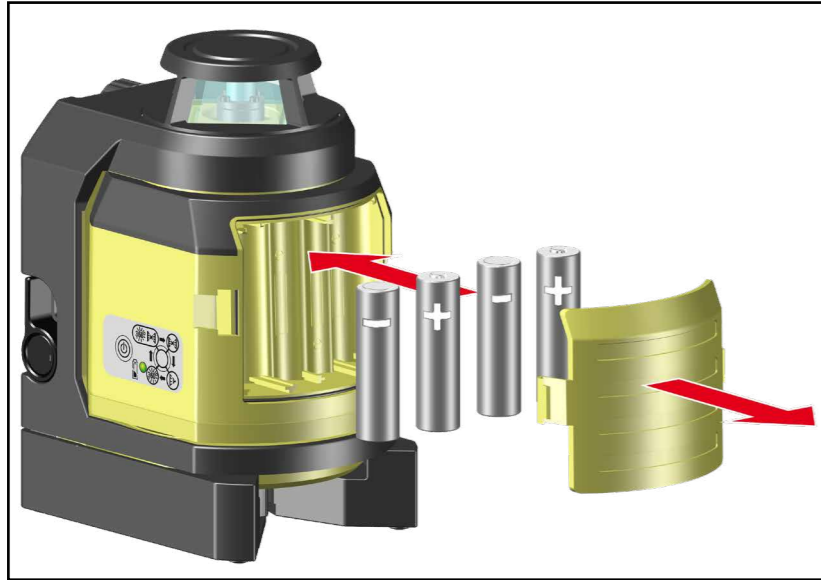

4 x 1.5 V
Alkaline
AA, LR6, Mignon

6. Inserting / Replacing the battery

Open battery compartment lid (16) in the direction of the arrow, insert new batteries as indicated by the symbol in the battery compartment. Suitable rechargeable batteries can also be used.

LED display:

Yellow LED (12): low battery charge - insert new battery



Dispose of used batteries at suitable collection points - not with household waste.

Remove the batteries if you do not intend to use the unit for some time!

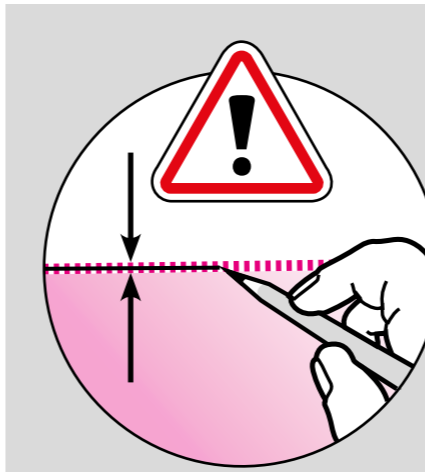
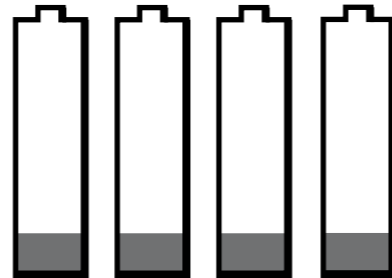
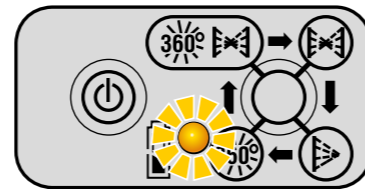
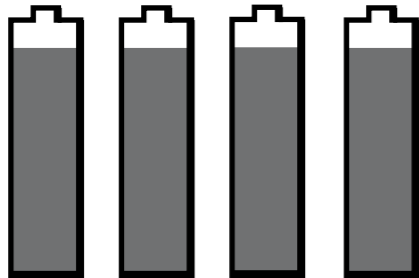
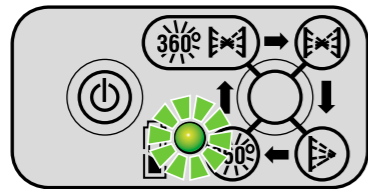

Always use the centre of the laser line when marking and aligning!

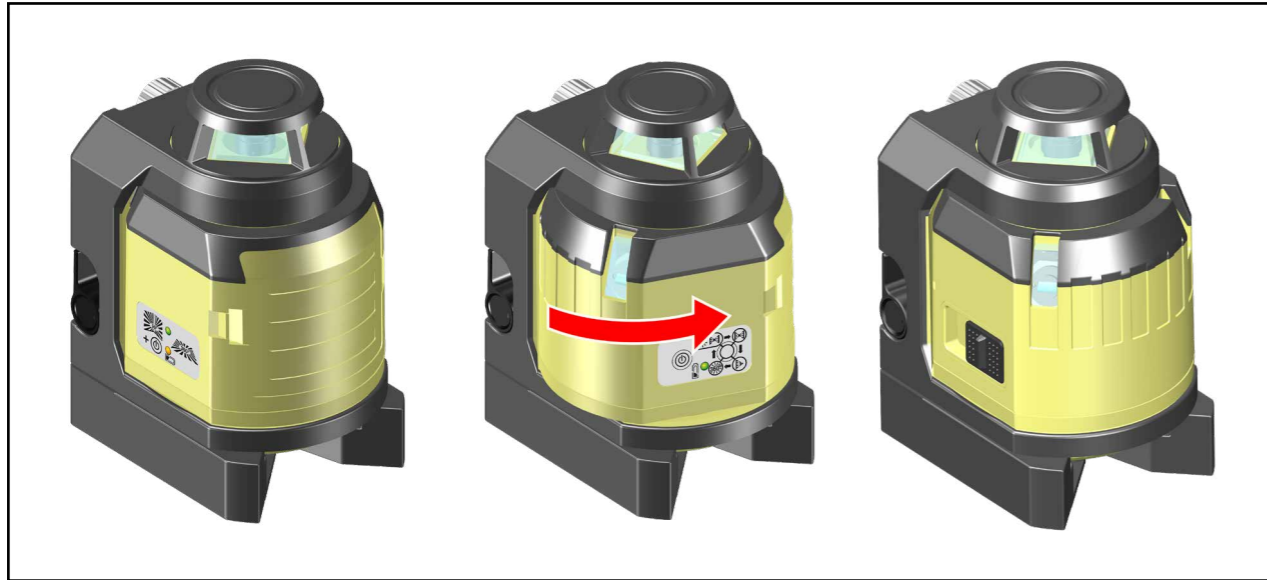

7. Commissioning with levelling function

Turn the laser casing to the working position. Use the sliding switch (9) to switch on the laser unit. Horizontal and vertical laser lines and the plumb-line laser dot appear. The LED lights up green. The LAX 400 is in self-levelling mode and levels itself automatically.

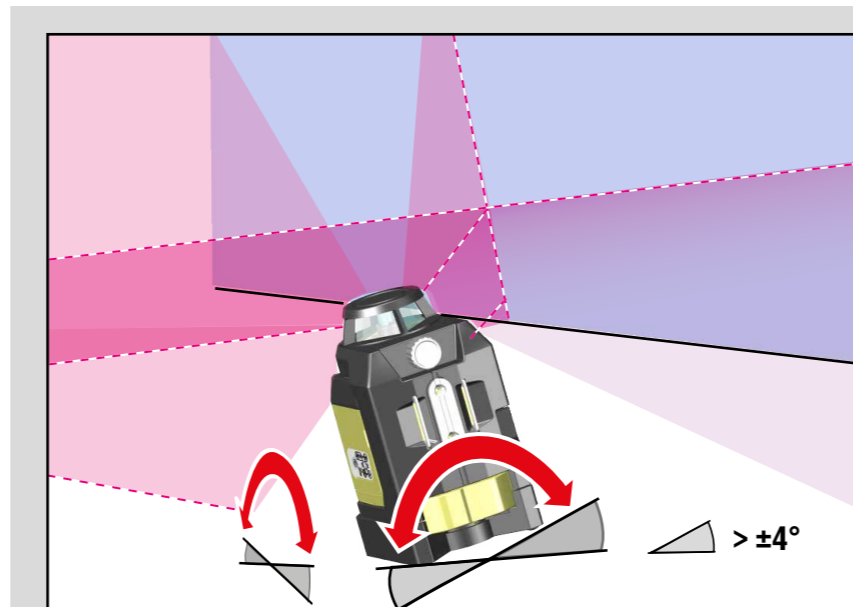
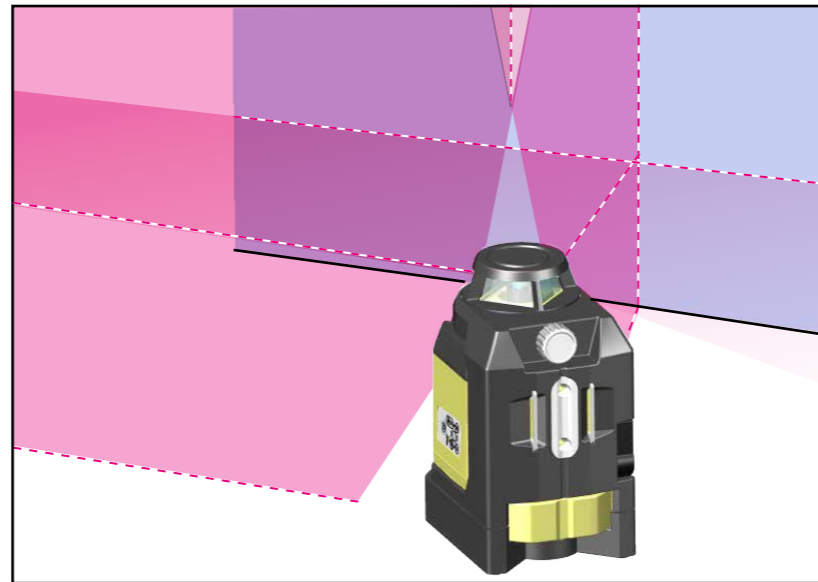
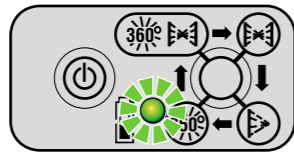
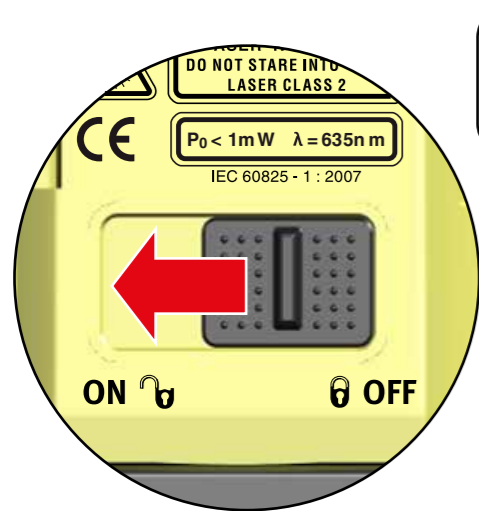

The laser lines flash if the laser unit is at too steep an angle. The laser unit is outside the self-levelling range and cannot level itself automatically.

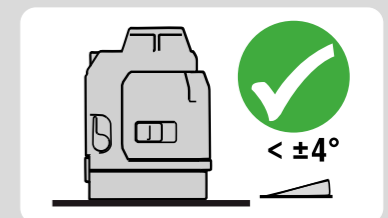
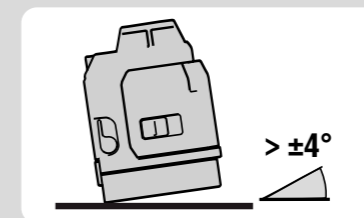

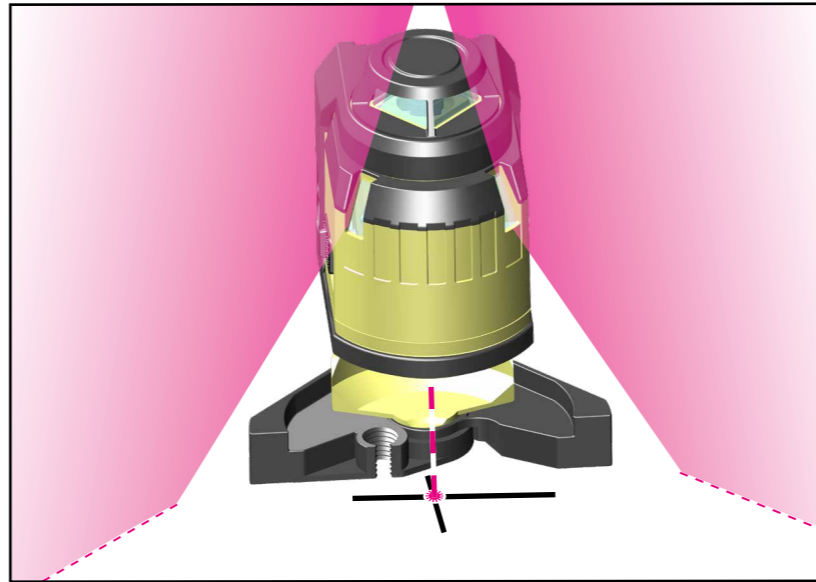
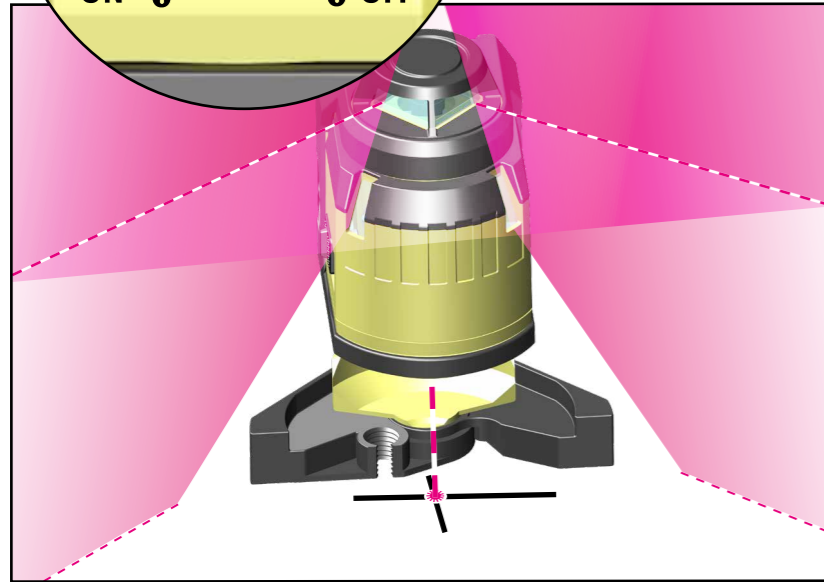
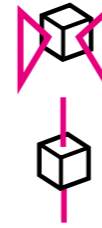
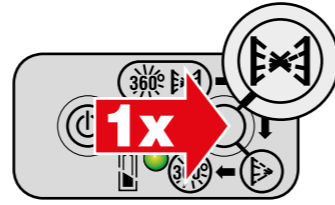
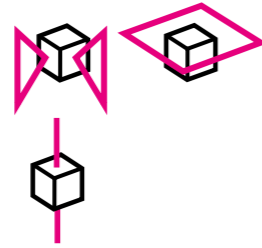
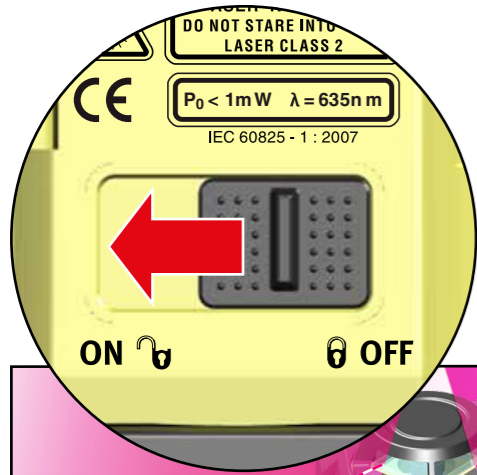

8. Selecting the laser functions

Once the unit has been switched on using the sliding switch (9), use button (11) to switch between the various laser functions.

8.1 Levelling functions:

- 2 x vertical laser lines at a 90° angle
- 1 x 360° horizontal laser line
- 1 x plumb-line function

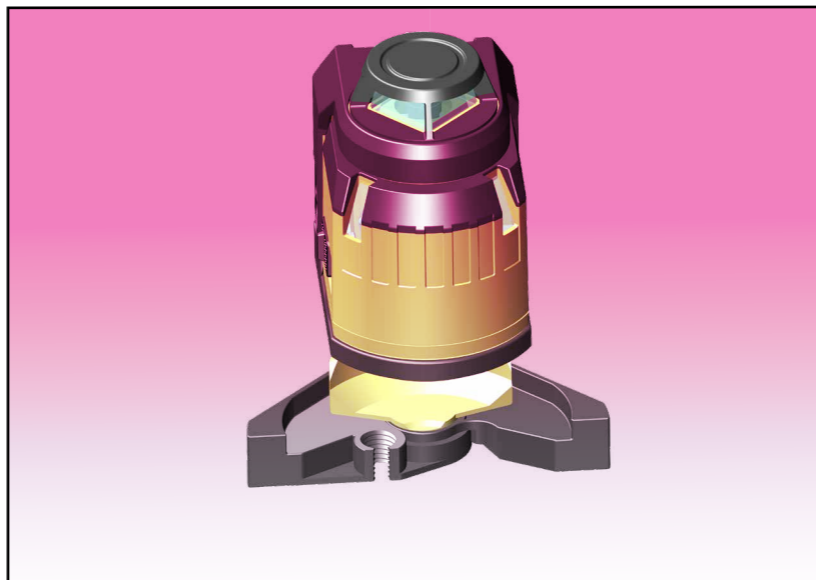
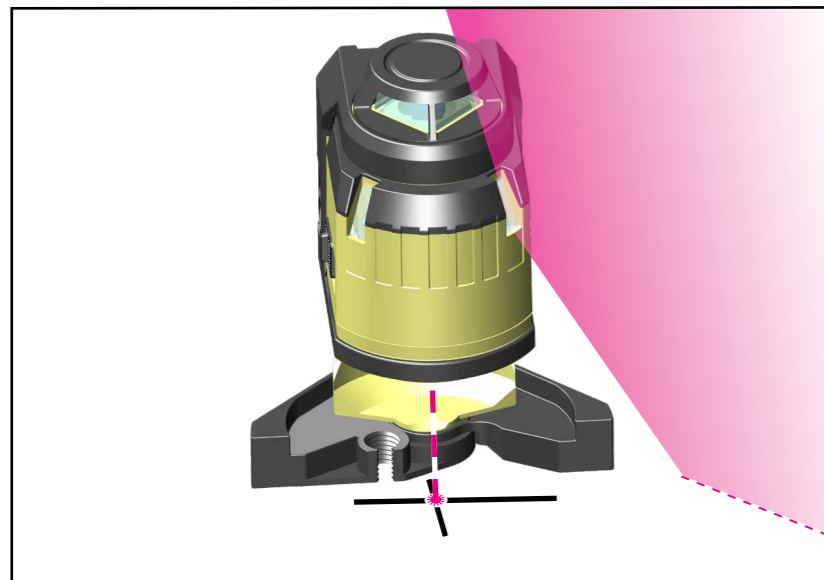
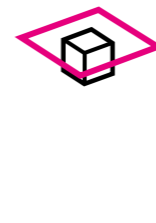
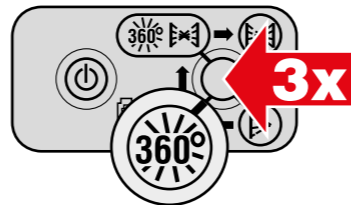
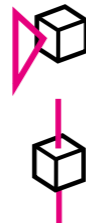
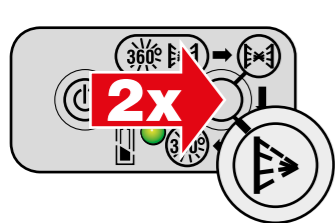

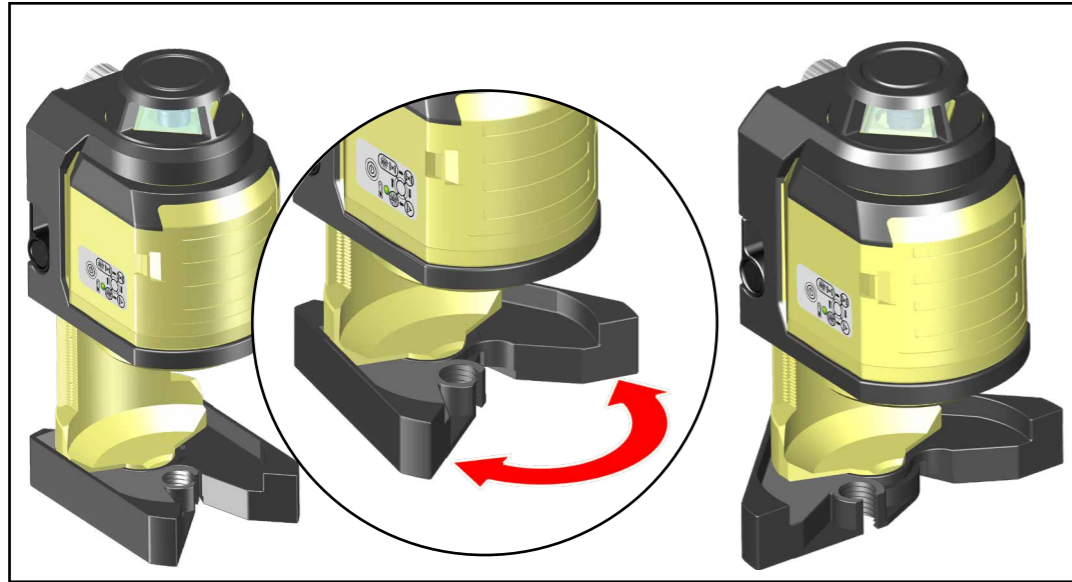

8.2 Plumb-line laser function:

The plumb-line dot will be clearly visible after the laser casing has been pushed up and the feet spread apart (7). This can be used to position the LAX 400 precisely.

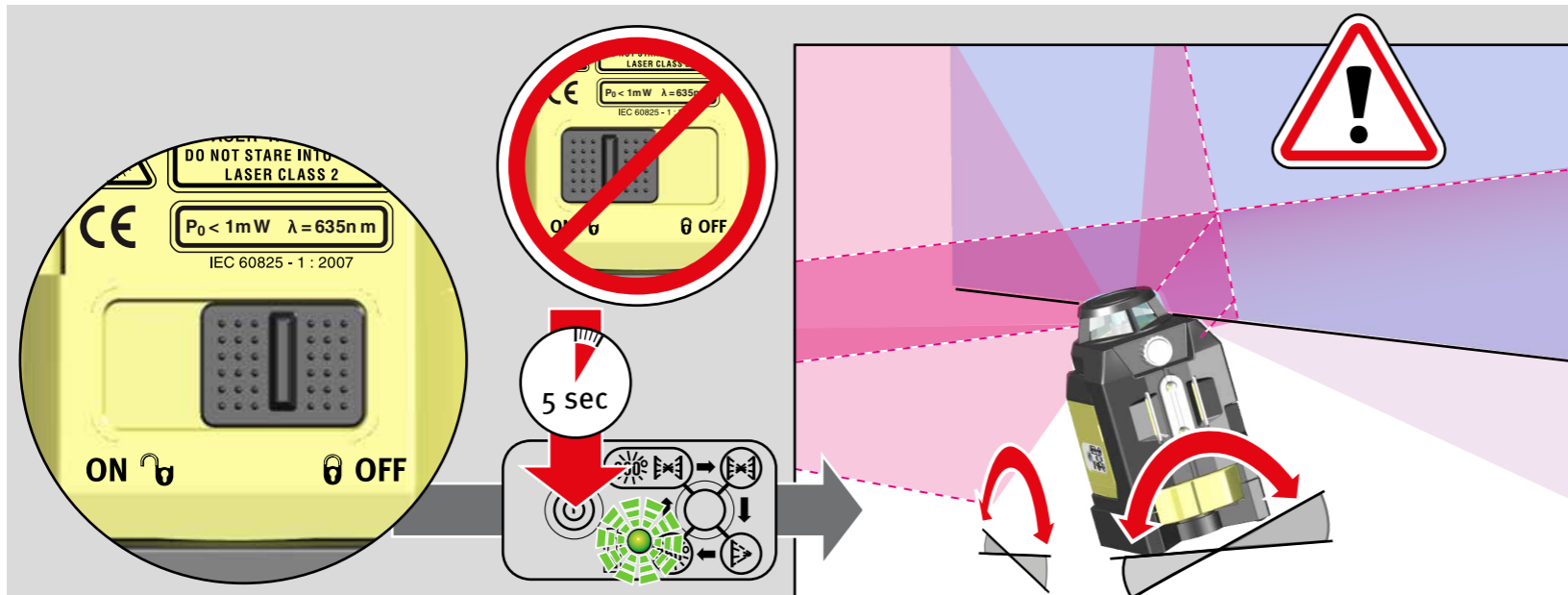
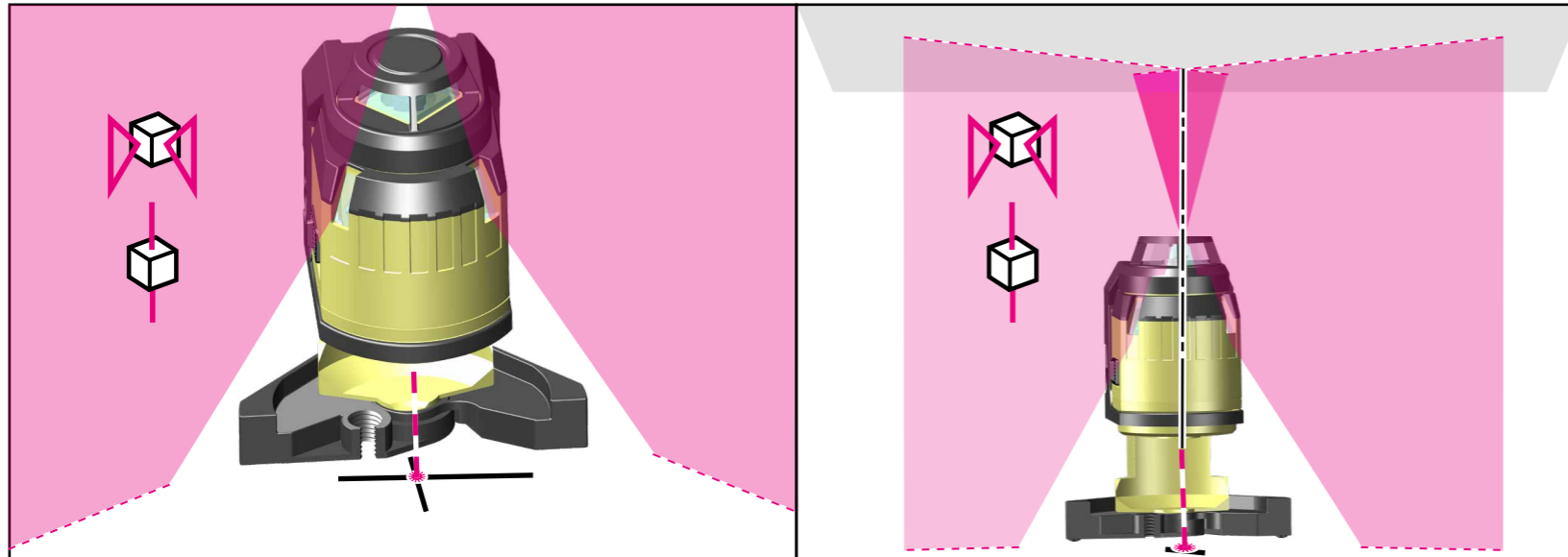

9. Commissioning without levelling function

Only use the button (10) to switch on the LAX 400 in Marking function mode. The horizontal and vertical laser lines, plumb-line dot and LED flash quickly. The LAX 400 is not in self-levelling mode and can only be used in this mode for marking and alignment!

Marking functions:

- 2 x vertical laser lines at a 90° angle
- 1 x 360° laser line
- 1 x dot laser

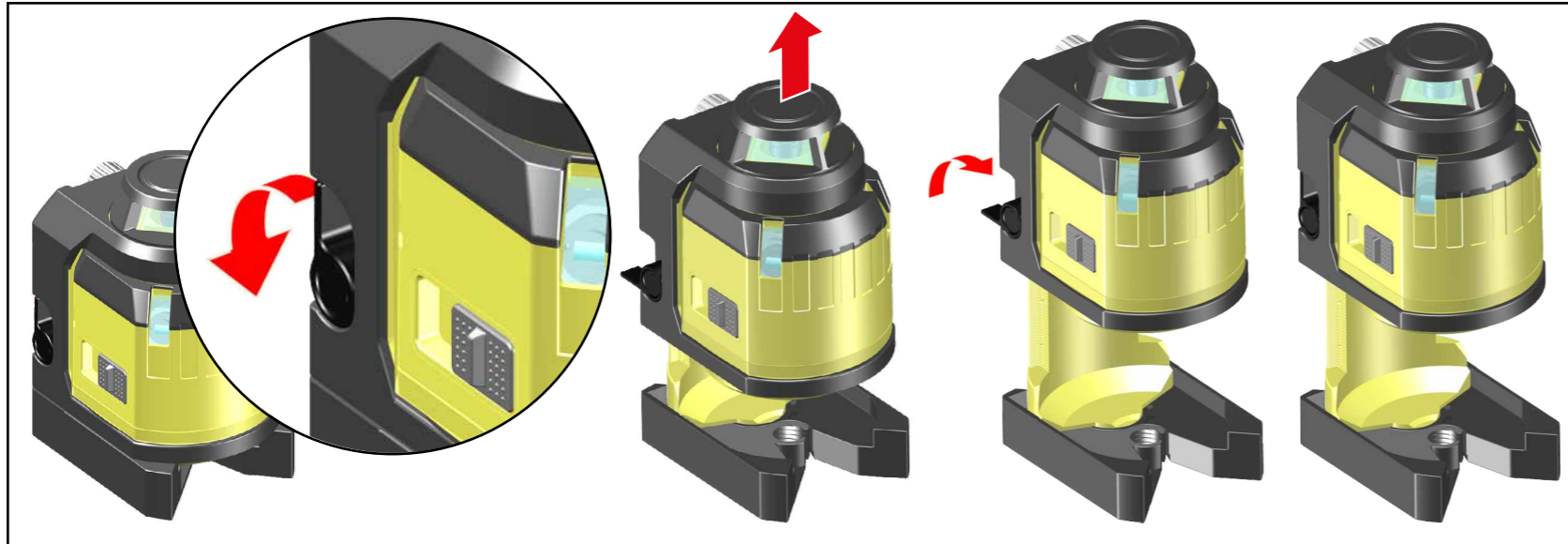

10 Additional functions

10.1 Function: Height adjustment

Use the clamping lever (4) to adjust the height of the laser casing.

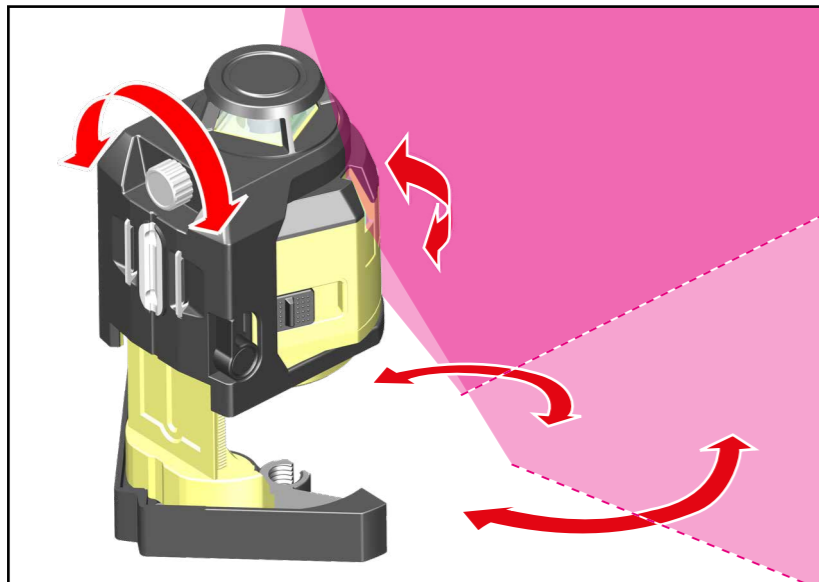

10.2 Function: Fine adjustment

Use the fine adjustment (2) to rotate the laser casing to an exceptionally high degree of precision, which allows the vertical lines to be precisely aligned.

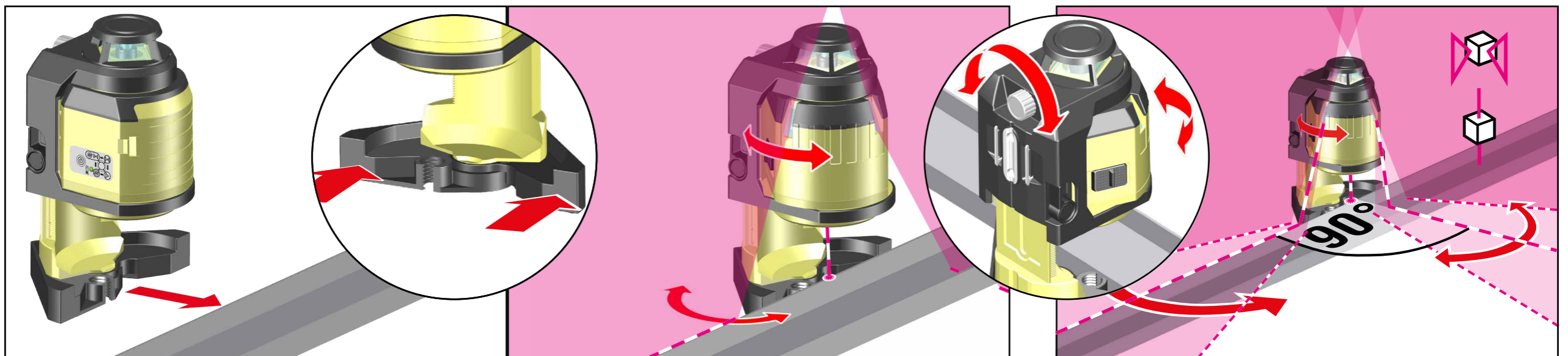

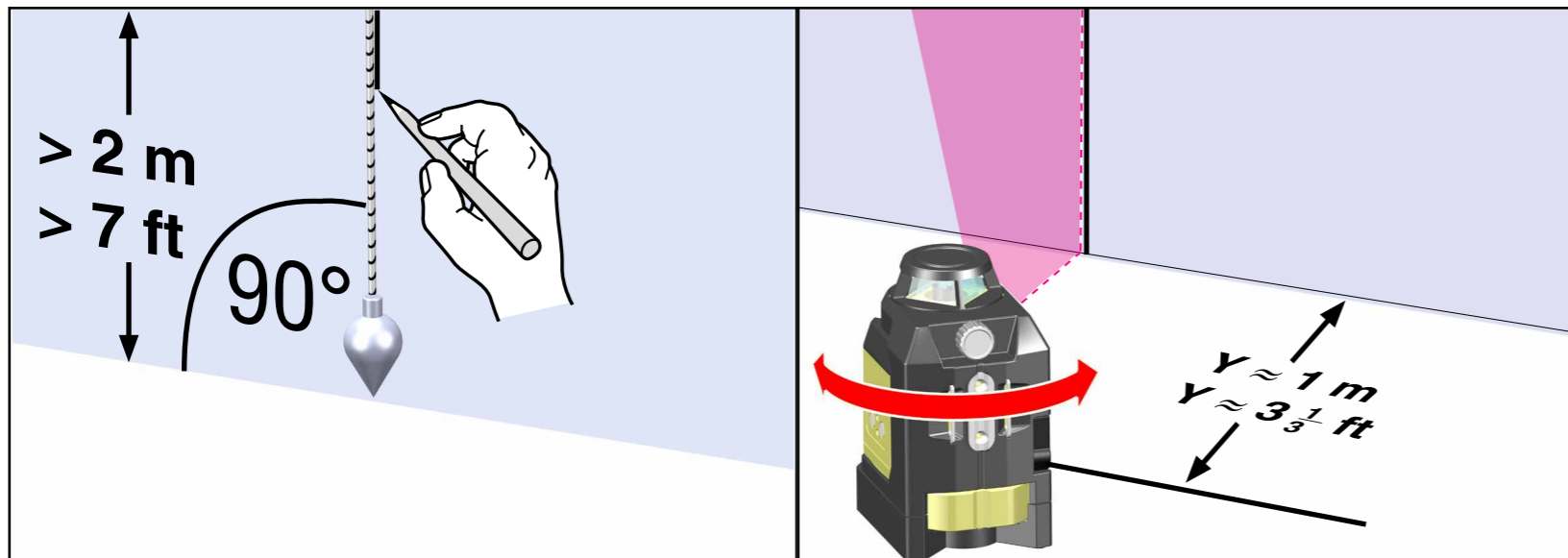

11. Checking the accuracy

The LAX 400 multi-line laser is designed for use on building sites and is perfectly adjusted before leaving our premises. Regularly check the calibration of the accuracy, as is the case with all precision instruments. Always check the unit before starting work, especially if it has been exposed to heavy vibrations.

- Vertical check
- Horizontal check
- Angle check

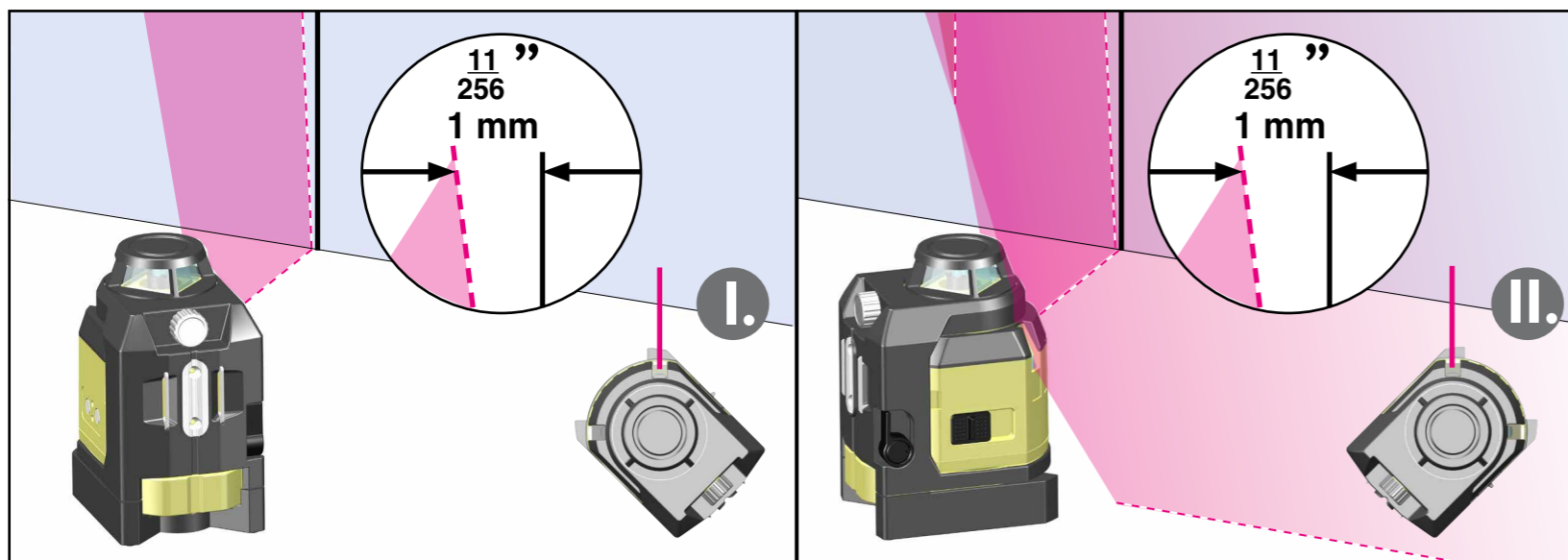

11.1 Vertical check

Checking the 2 vertical laser lines

1. Create a reference line, e.g. with a plumb line.
2. Set up and align the LAX 400 at distance Y in front of this reference line.
3. Compare the laser line with the reference line.
4. Do not allow the laser line to deviate from the reference line by more than 1 mm (11/256") over a distance of 2 m (7')!
5. Perform this check for both vertical laser lines.

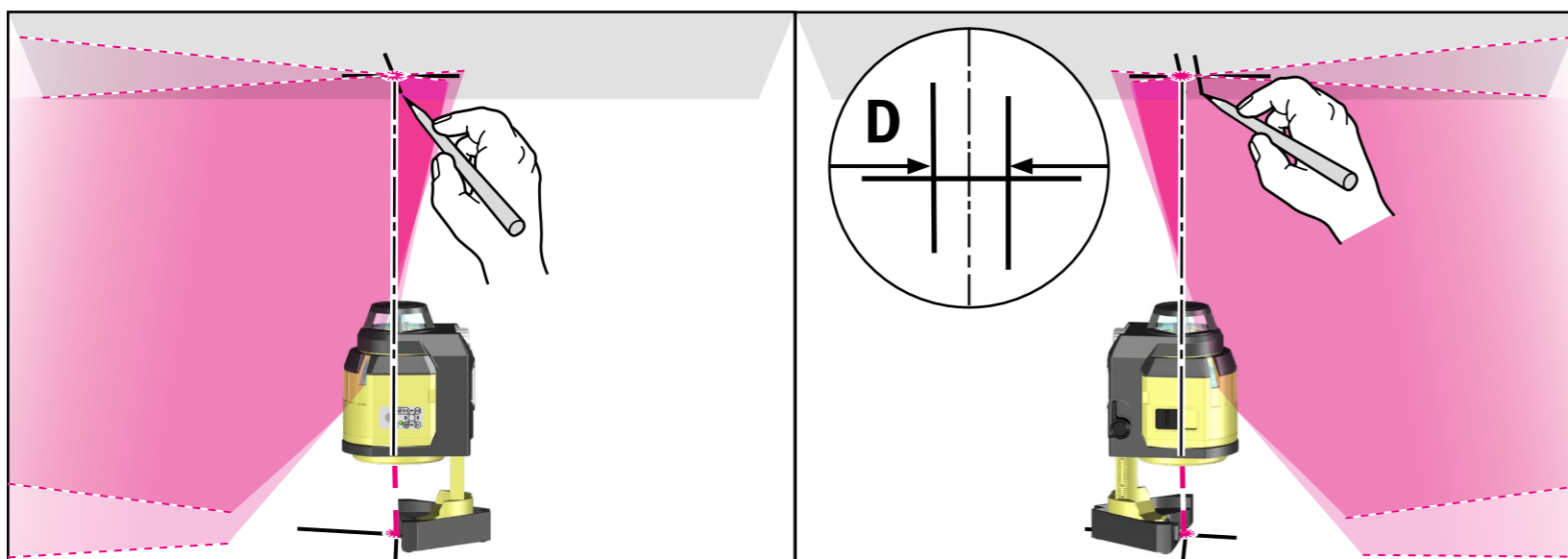

Checking the plumb-line function

1. Align the LAX 400 precisely with one floor marking using the plumb dot.
2. The projected laser line cross appears on the ceiling.
3. Turn the LAX 400 around 180° and align it once again with the floor marking using the plumb-line dot.
4. The projected laser line cross appears on the ceiling.
5. The difference measured between the markings is twice the actual discrepancy. With a ceiling height of 5 m (16'5"), the difference should be no more than 3 mm (1/8").

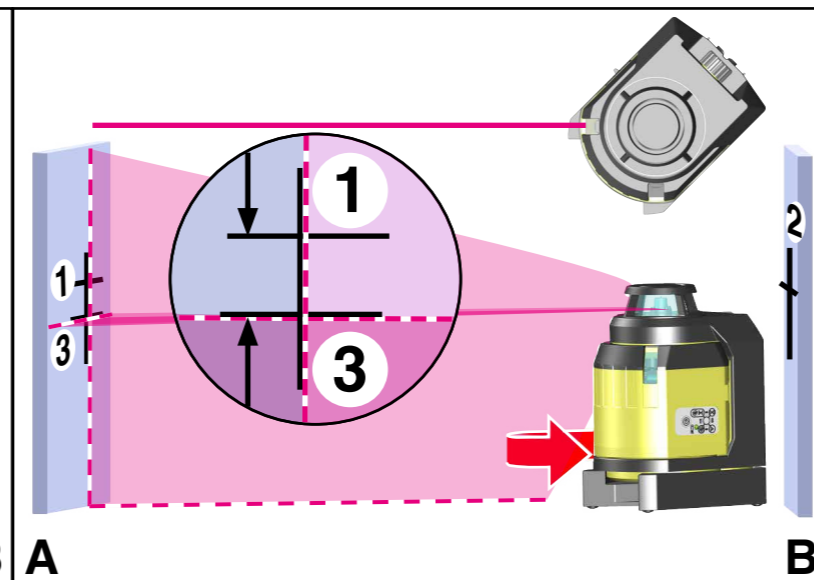
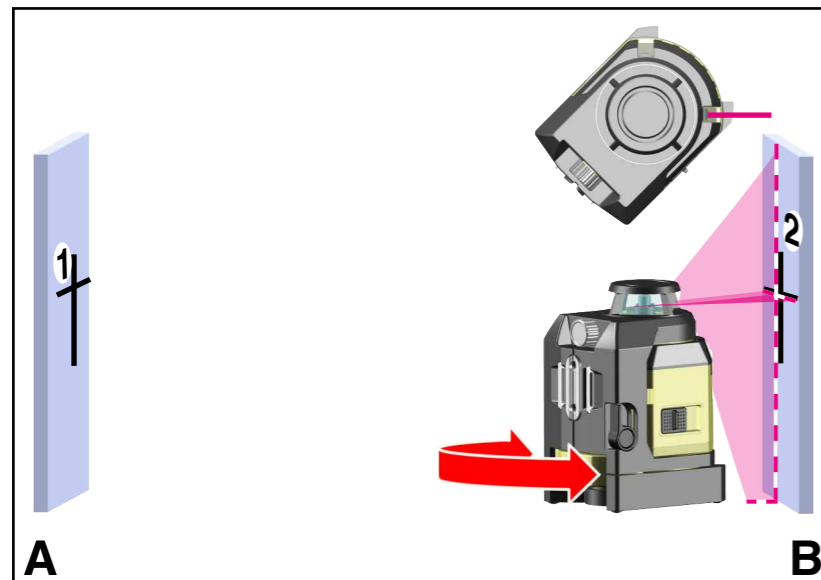
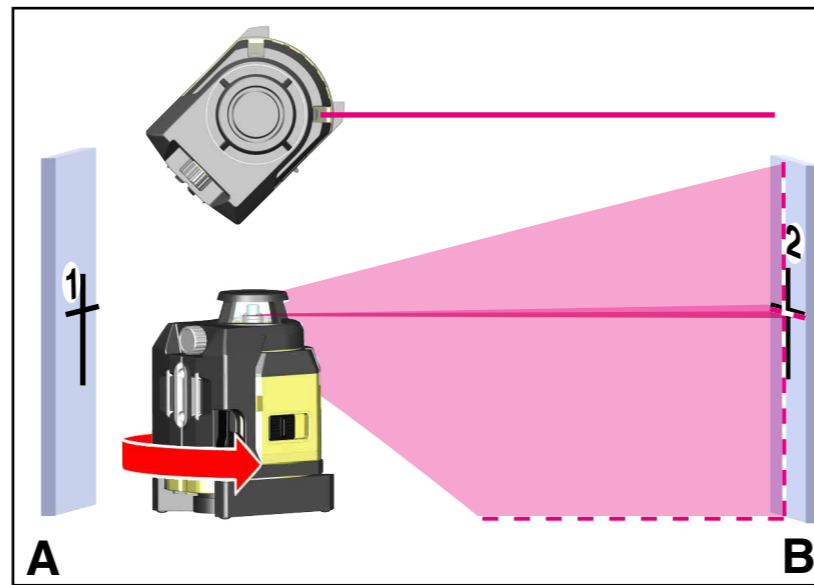
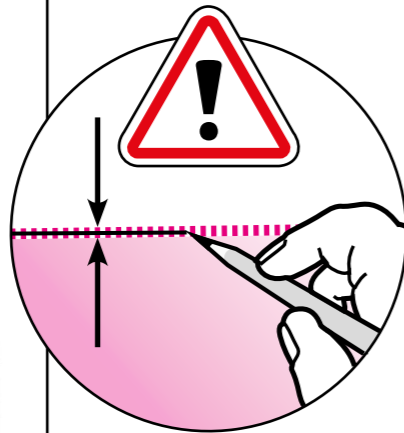
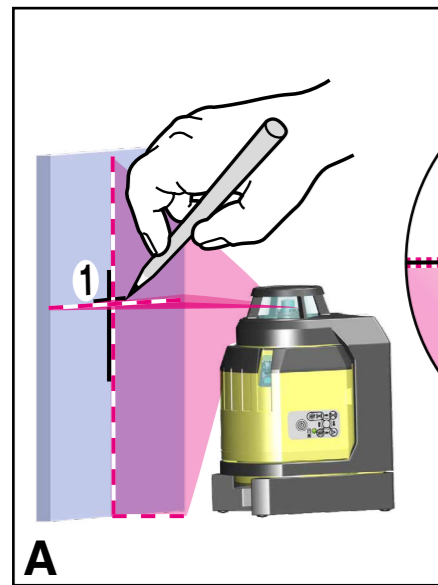
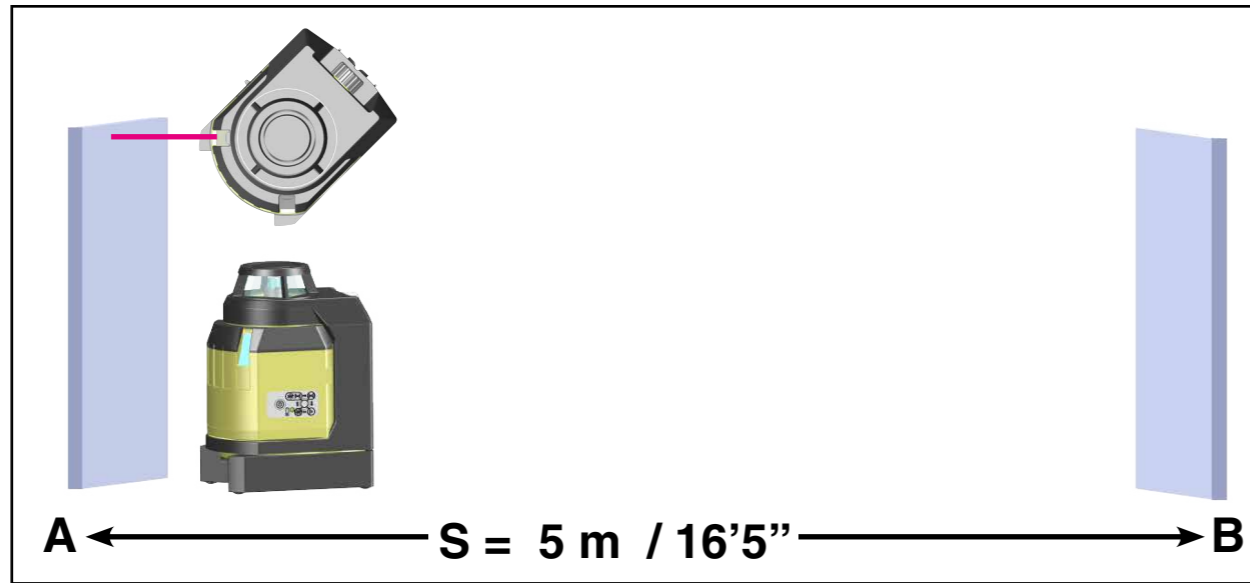
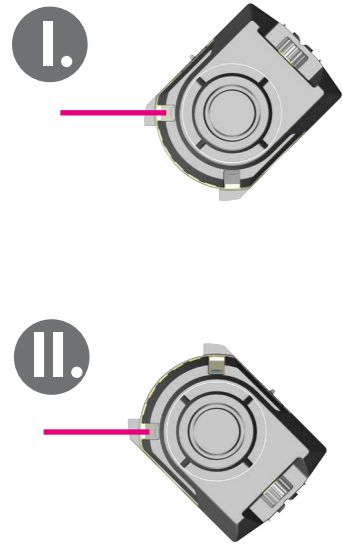

11.2 Horizontal check

Checking the level of the horizontal laser line

2 parallel walls at a distance S of at least 5 m (16'5") apart are needed to carry out the horizontal check.

1. Position the LAX 400 as close as possible to wall A on a horizontal surface.
2. Use an exit window for a vertical laser line to align the LAX 400 with wall A.
3. Switch on the laser unit (sliding switch 9)
4. Once automatic levelling has ended, mark the cross projected onto wall A. Point 1.
5. Turn the LAX 400 around 180° and align with wall B using the same vertical laser line exit window. Do not adjust the height.
6. Once automatic levelling has ended, mark the cross projected onto wall B. Point 2.
7. Now reposition the laser unit so that it is directly in front of wall B. Align the LAX 400 with wall B using the same exit window for a vertical laser line.
8. Move the laser line cross by turning and adjusting the height until it precisely coincides with point 2.
9. Turn the LAX 400 round 180° and align with wall A using the same vertical laser line exit window. Do not adjust the height.
10. Move the laser line cross by turning the casing until it precisely coincides with the marking line of point 1.
11. Once automatic levelling has ended, mark the cross projected onto wall A. Point 3.
12. Measure the vertical distance between points 1 and 3. Perform this check with both vertical laser lines!

Distance S to the wall	Maximum permissible distance:
5 m	3.0 mm
10 m	6.0 mm
15 m	9.0 mm
16'5"	1/8"
32'10"	1/4"
49'3"	3/8"



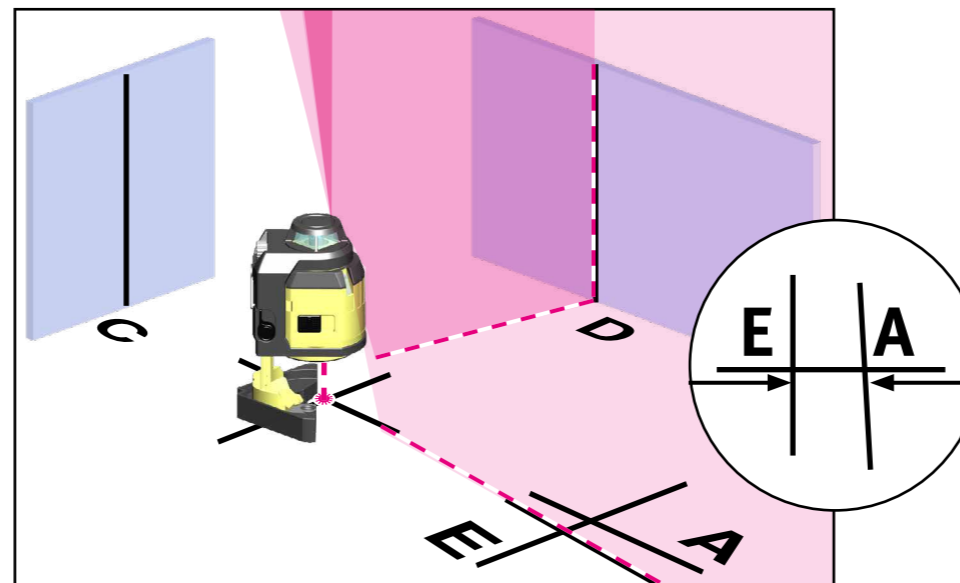
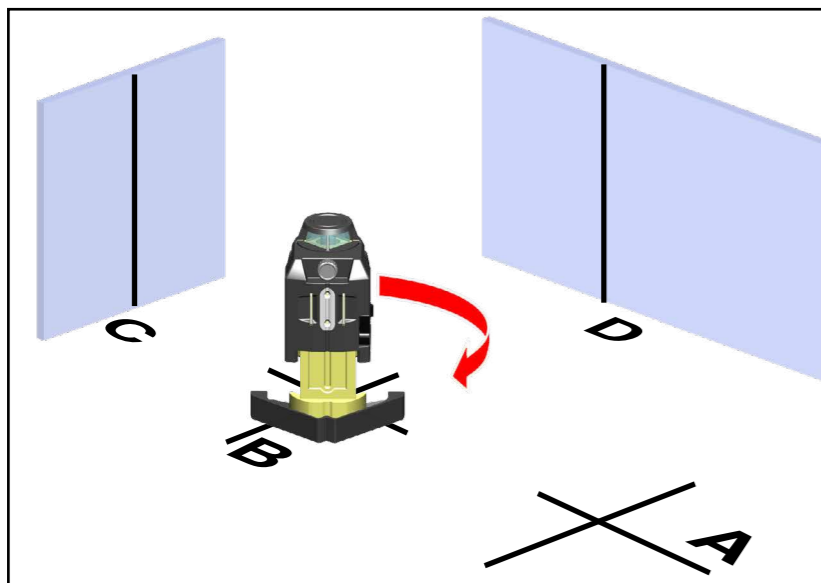
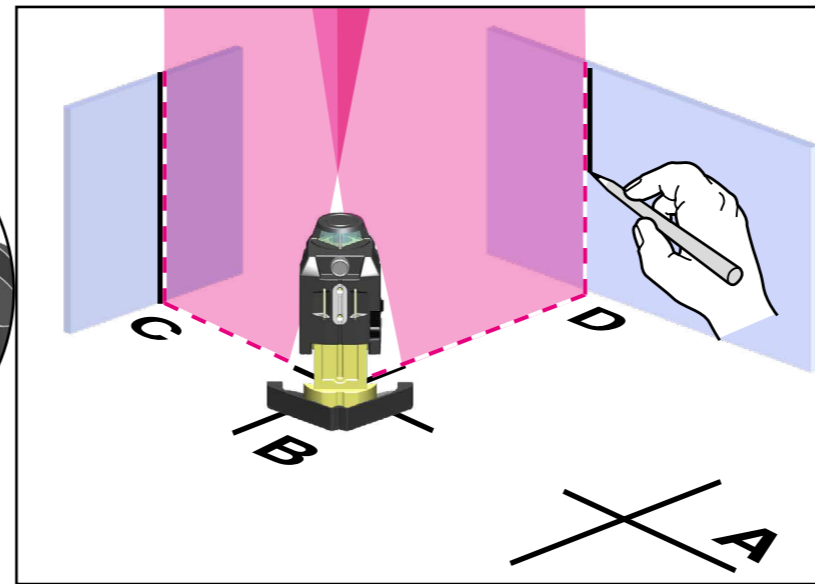
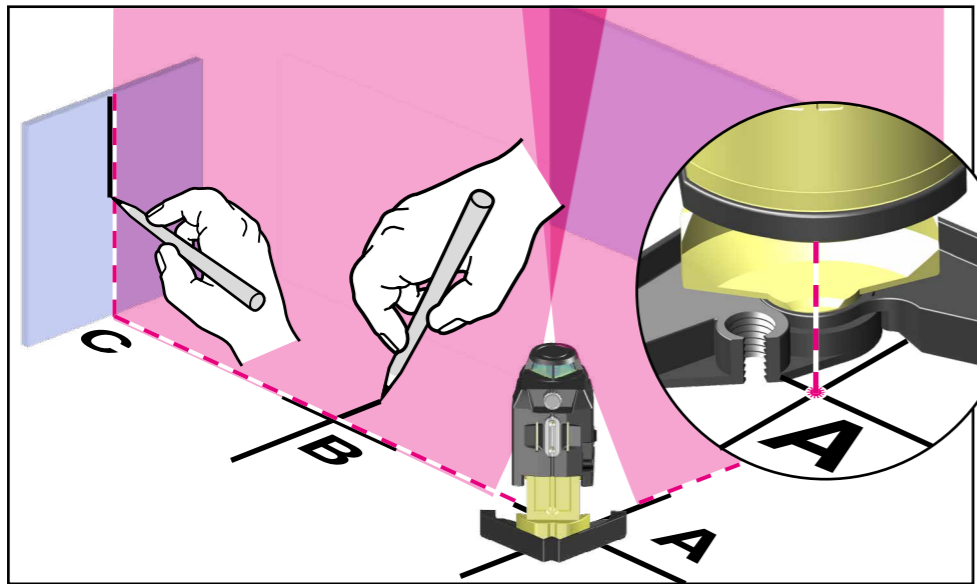
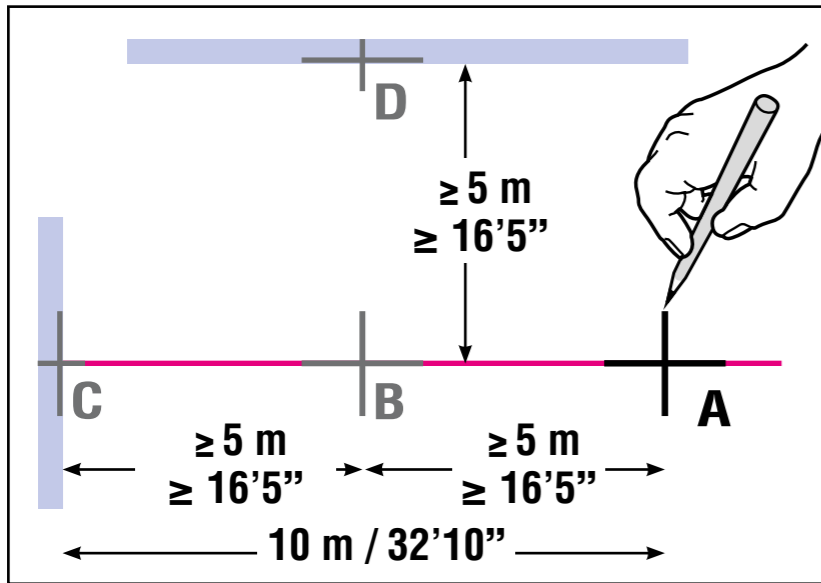

11.3 Angle check

Checking the 90° angle

1. Mark point A on the floor at a distance of 10 m (32'10") in a sufficiently large corner of the room.
2. Align the LAX 400 with point A using the plumb-line dot.
3. Align the LAX 400 with the one wall using a laser line.
4. Precisely mark point B on the floor at the halfway point.
5. Precisely mark point C on the wall or floor.
6. Shift the LAX 400 and align with point B using the plumb-line dot.
7. Align the LAX 400 with point C again using the laser line.
8. Precisely mark point D on the other wall or on the floor using the 90° laser line.

Note:

The distance from A to B, B to C and B to D should be the same to guarantee accuracy.

9. Turn the LAX 400 through 90° and align laser line 1 with point D.
10. Mark position E on the perpendicular 2nd laser line as close as possible to point A.
11. Measure the distance between points A - E.

Room length or distance between points A and C	Maximum permissible distance between points A and E
10 m	3.0 mm
20 m	6.0 mm
32'10"	1/8"
65'8"	1/4"

12. Technical data

Laser type: Red diode laser, pulsed line laser,
wave length 635 nm

Power output: < 1 mW, laser class 2 in accordance with IEC 60825-1:2007
This product compl. with the appl. requ. of 21CFR, parts 1040.10 and 1040.11.

Self-levelling range: approx. $\pm 4^\circ$

Levelling precision*:

Horizontal laser line: ± 0.3 mm/m $\pm 3/16''$ over 50ft centre of laser line

Laser line inclination: ± 0.2 mm/m $\pm 1/8''$ over 50ft laser line

90° precision: ± 0.3 mm/m $\pm 3/16''$ over 50 ft

Vertical intersection: ± 0.3 mm/m $\pm 3/16''$ over 50 ft

Plumb-line beam facing downwards: ± 0.3 mm/m $\pm 3/16''$ over 50 ft

Batteries: 4 x 1.5 V alkaline, size Mignon, AA, LR6

Operating life: approx. 10 hours (alkaline)

Operating temperature range: -10°C to $+50^\circ\text{C}$ / 14°F to $+122^\circ\text{F}$

Storage temperature range: -25°C to $+70^\circ\text{C}$ / -13°F to $+158^\circ\text{F}$

Subject to technical modifications.

* when operated within the specified temperature range

Europe
Middle and South America
Australia
Asia
Africa



STABILA Messgeräte
Gustav Ullrich GmbH

P.O. Box 13 40 / D-76851 Annweiler
Landauer Str. 45 / D-76855 Annweiler

☎ + 49 63 46 309 - 0
✉ info@de.stabila.com

USA
Canada

STABILA Inc.

332 Industrial Drive
South Elgin, IL 60177

☎ 800-869-7460
✉ custservice@Stabila.com